



BASF

We create chemistry

Thermoplastic Polyurethane Elastomers (TPU)

Elastollan® – Processing Recommendations

Elastollan®

Elastollan® is the brand name for thermoplastic polyurethane (TPU) from BASF. It stands for maximum reliability, consistent product quality and cost efficiency. The material can be extruded to produce tubings, cable sheathings, belts, films and profiles, and can also be blow molded and injection molded. Aromatic or aliphatic, with maximum softness or glassfiber reinforcement, flame retardancy or high transparency – the versatility of Elastollan® has been proven over the course of many years in all sectors of industry.

The extensive product range is based on a wide range of feedstocks and formulations, and provides the basis for successful implementation of innovative projects by our customers.

We thrive on creative ideas and complex challenges – come and talk to us!

GENERAL RECOMMENDATIONS			4-9
	Storage	4	
	Drying	5	
	Coloring	6	
	Additives	6	
	Use of Regrind	6	
	Post-treatment	7	
	Health & Safety at Work	9	
	Disposal	9	
INJECTION MOLDING			10-15
	Machine Design	10	
	Processing Parameters	10	
	Mold Design	12	
	Shrinkage	14	
	Inserts	14	
	Special Processing Methods	14	
	Troubleshooting	15	
EXTRUSION			16-21
	Machine Design	16	
	Processing Parameters	17	
	Die Design	18	
	Cooling and Calibration	19	
	Extrusion Techniques	19	
	Special Processing Methods	21	
	Troubleshooting	21	
DOWNSTREAM OPERATIONS			22-23
	Welding	22	
	Bonding	22	
	Surface Finishing	22	
	Machining Parameters	22	
	Chipping Machining	22	
	Chipless Machining	23	
QUALITY MANAGEMENT			24
INDEX OF KEY TERMS			26-27

General Recommendations

Storage

Elastollan® is the registered trademark of our thermoplastic polyurethane elastomers (TPU). These materials are used for injection molding, extrusion and blow molding.

The following recommendations should be followed during processing of Elastollan®: Elastollan® is supplied uncolored in diced, cylindrical or lenticular form. The material is hygroscopic: dry Elastollan® therefore very rapidly absorbs moisture from the atmosphere unless it is stored in sealed packaging.

Figures 1 and 2 show the rate of moisture absorption of polyester- and polyether-based Elastollan®. It is therefore advisable to store the granulate in dry conditions, ideally at room temperature.

We recommend that material stored at below room temperature is brought to room temperature before the packaging is opened. Any possible condensation of moisture can thus be prevented.

Packaging should always be resealed after removal of product. The granulate should be exposed to the atmosphere only for as long as absolutely essential. It is therefore important to cover the feed hopper on processing machines. Our general recommendation is drying of the granulate to <0.02 % moisture content before processing. The granulates mostly require drying after repeated opening of packaging.

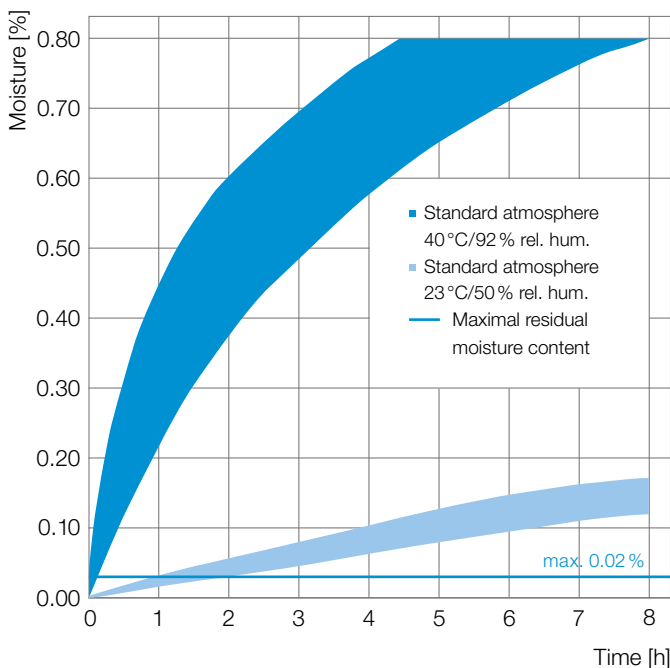

Fig. 1: Moisture absorption: Polyester TPU
Hardness 80 Shore A – 64 Shore D

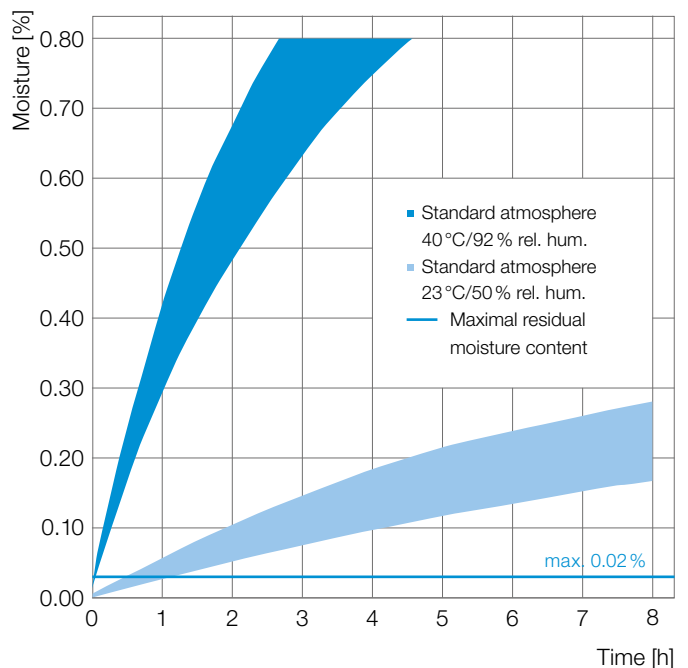

Fig. 2: Moisture absorption: Polyether TPU
Hardness 80 Shore A – 64 Shore D

Drying

Excessive moisture content in granulate leads to processing problems and reduced finished product quality.

Indications of excessively high moisture content include foaming of the plastified material or formation of gas bottles in the melt. Insufficient predrying is often the cause of through-put variations during extrusion, or die drooling.

For optimized performance of Elastollan® products, it is necessary to dry the material before processing. **The water content of the granulate should be below 0.02 %!**

Conventional circulating-air dryers and dehumidified-air dryers are suitable for this purpose. See table 1 for recommended drying parameters.

When circulating-air dryers are used, the height of the granulate layer should not be more than 4 cm. When dehumidified-air dryers are used, full utilization of the available capacity can be achieved.

If color masterbatches and other additives are used, the same drying requirements apply to these. It is therefore advisable to add these materials to the granulates before drying. This ensures that the entire material is dry.

Drying recommendations

Elastollan® hardness	Drying time	Drying temperature	
		Circulating air	Dehumidified air
Polyether/Polyester TPU			
Shore A 70-90	3-4 hours	90-110 °C	90-100 °C
Harder than Shore A 90	3-4 hours	100-120 °C	90-120 °C
Aliphatic TPU	3-5 hours	Not suitable	40-60 °C
HPM product range	3-5 hours	Not suitable	60-80 °C

Table 1: Drying recommendations (please refer to the information provided for the specific product)

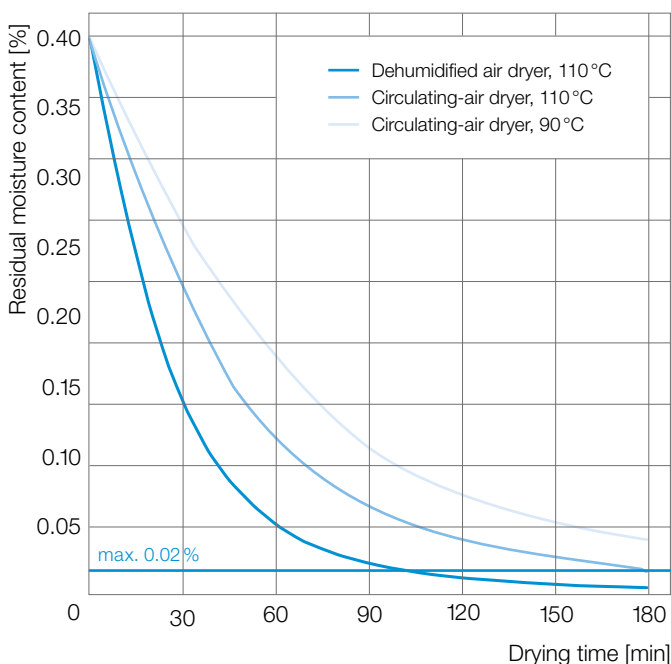

Fig. 3: Drying graph for Elastollan®

Coloring

All grades in our Elastollan® range can be colored. TPU-based color masterbatches are most suitable for this purpose. When the color masterbatches used are based on Elastollan®, the quantity added is normally 1 to 2%.

Elastollan® grades containing pre-included additives (e.g. flame retardant) can require a higher percentage loading to achieve full color depth.

In the case of color masterbatches not based on TPU, there may be a risk of incompatibility with Elastollan®. This can result in poor pigment dispersion and lack of coloring strength, and possibly also poor surface finish and other quality problems.

Additives

Various additives can be used to enhance the properties of Elastollan® materials.

Some of the additives available in the form of Elastollan® masterbatches are:

- Antiblocking agents
- Release agents
- UV stabilizers
- Abrasion modifiers

Use of Regrind

Up to 30%, depending on required product quality, can be recycled with virgin material. Material type and Shore hardness of the regrind must match the virgin Elastollan®, and it must be free from contamination.

Regrind should ideally be diced, dried and re-used without intermediate storage.

Material which has been contaminated or degraded is not suitable for reprocessing.

Multiple recycling of regrind can lead to reduced product quality. Particular specified quality requirements may exclude use of regrind.

Post-treatment

For optimized performance, **annealing** of the products is required. This heat treatment can be undertaken in a circulating-air oven.

Figures 4 to 6 show typical values for the effect of annealing on the properties of Elastollan® grades. In order to avoid deformation of products with low dimensional stability, these should be suitably supported during annealing.

Extruded products are annealed only in specific cases.

Annealing:

Recommended duration and temperature: 20h at 100°C

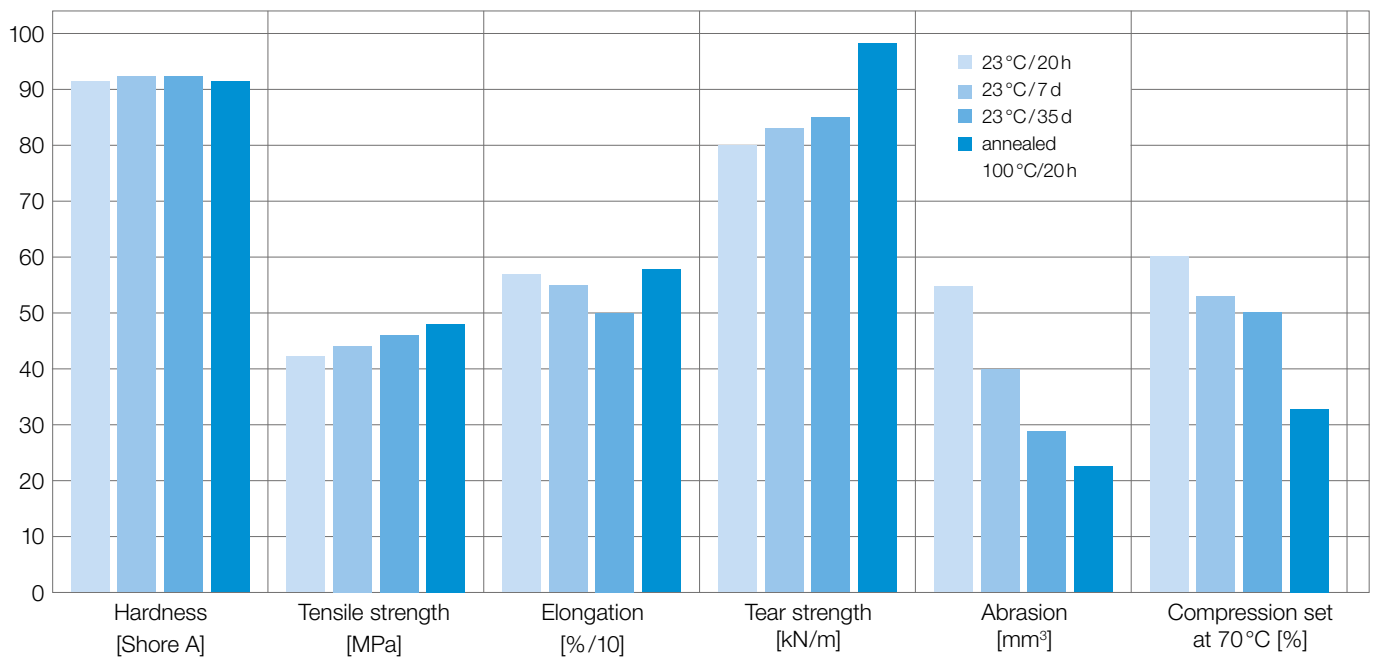

Fig. 4: Elastollan® C 90A 55

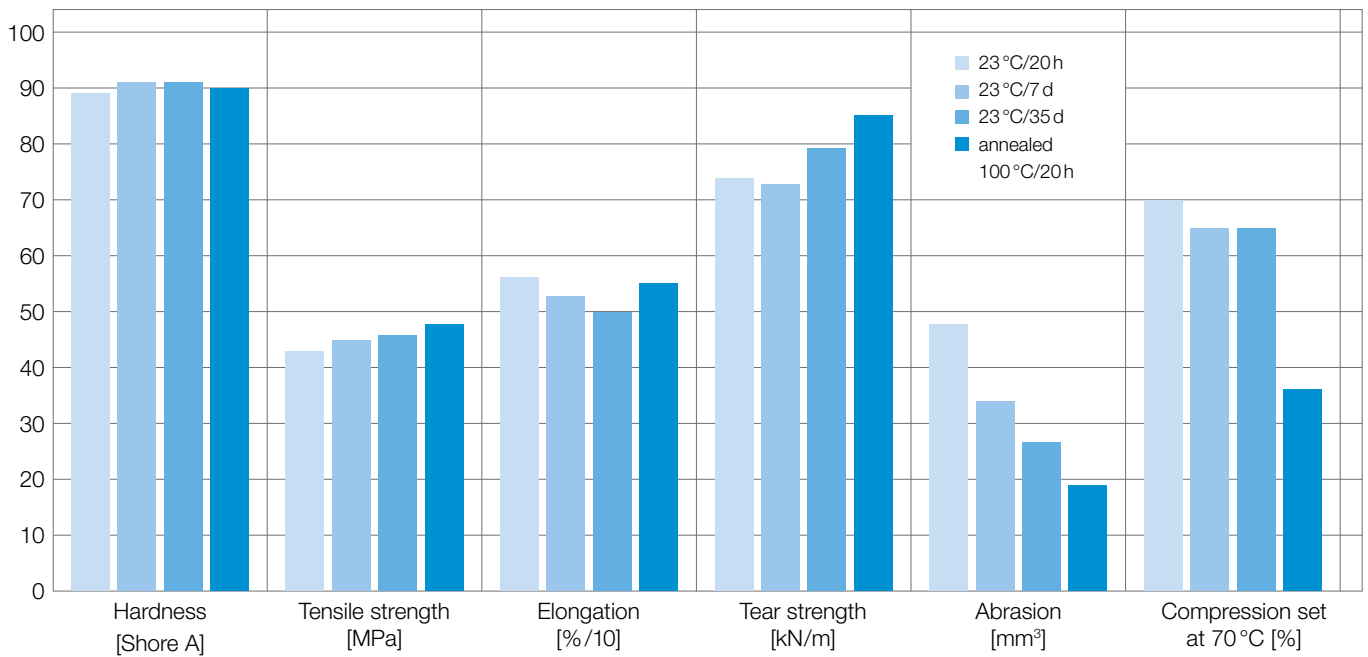

Fig. 5: Elastollan® 11 90A 55

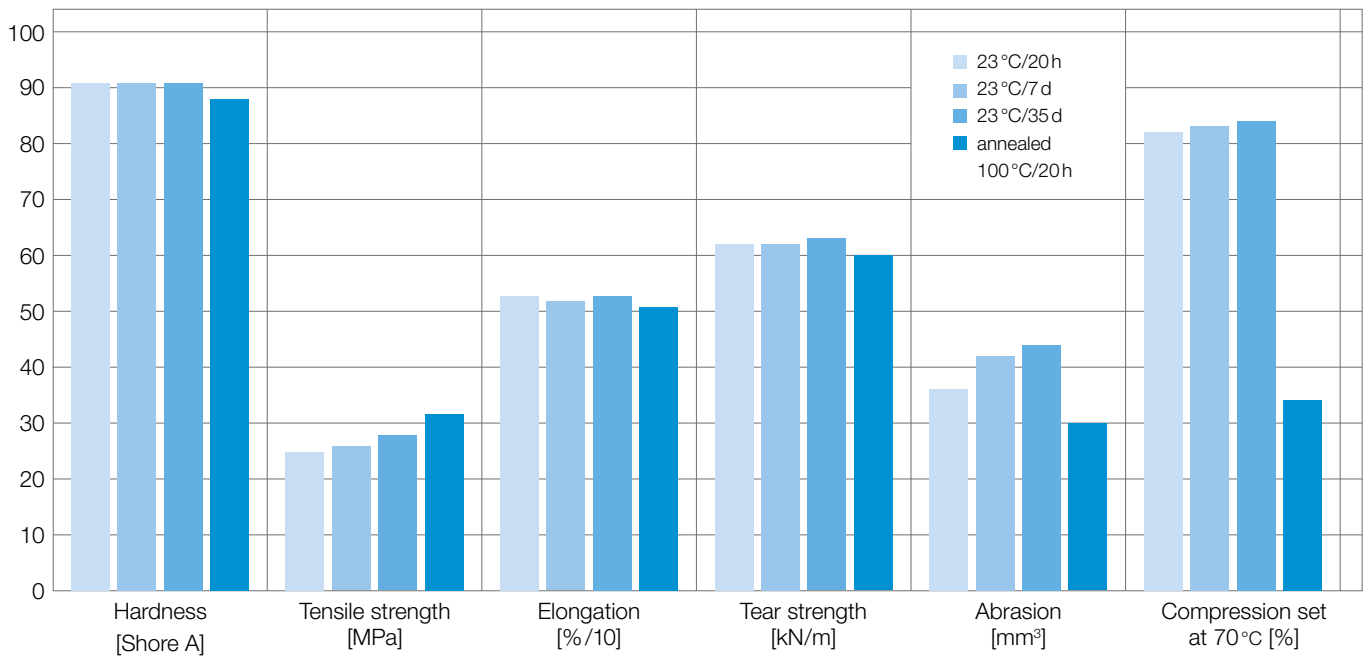

Fig. 6: Elastollan® 11 85A 10 FHF

Health & Safety at Work

Elastollan® can be processed at a wide range of temperatures, depending on the grade used.

As with all natural or synthetic organic substances decomposition can occur above certain temperatures. The extent of decomposition depends on the temperature and on the type of material used. Onset of decomposition can generally be expected from a temperature of about 230 °C upward. Particularly where elastomer melts are frequently exposed to the atmosphere, there is a possibility that vapors released under the above conditions will affect the workplace.

Use of an effective extraction system is therefore generally recommended, in particular in the region of melt discharge.

Disposal

Thermoplastic polyurethanes can generally be recycled to protect the environment (in each case after checking ecological, economic and product-safety aspects):

1. Materials recycling

TPU wastes or TPU moldings are regranulated for materials recycling. At most 30 percent of TPU regrind can be added to virgin granulate.

2. Thermal recycling

There are only a few thermoplastic polyurethanes that cannot be reused within the process. These TPUs are used to generate electricity in modern waste-incineration plants.

Injection Molding

Machine Design

Screw injection molding machines with single-flighted 3-zone screws are suitable for the processing of Elastollan®. Short-compression-zone screws are not suitable, because of high shear levels.

A successful screw design is shown below (see figure 7). To ensure continuous purging and to avoid dead spots it must be ensured during design that the non-driving flank in relation to the driving flank has a flatter radius.

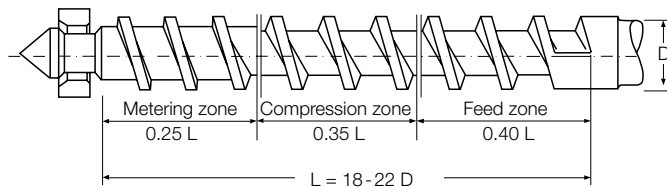

Fig. 7: Screw geometry (diagrammatic)

Compression ratio should be 1:2 and should never exceed 1:3. Recommended flight depths are shown in figure 8.

A check ring (shut-off ring) should be incorporated. It is preferable to use low-shear, free-flow and automatic-shut-off bolt-seal nozzles. The nozzle channel must be designed for easy flow, and must have no regions of restricted flow where the melt is held and can degrade to form deposits.

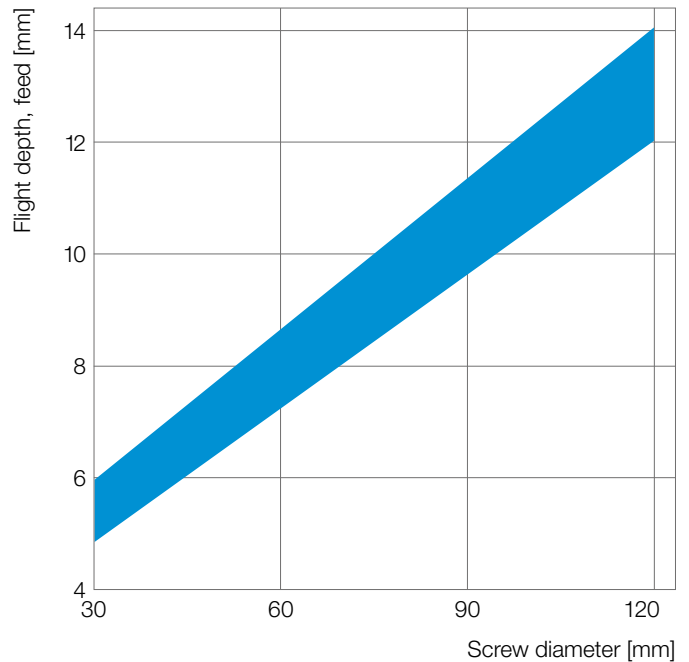

Fig. 8: Relationship between screw diameter and flight depth at feed

Processing Parameters

Problem-free processing of Elastollan® to provide products of uniformly high quality requires precise and constant temperature control in the injection-molding cylinder, adapter and nozzle.

The temperature should rise by about 10 to 20 °C from the feed zone to the metering zone. Nozzle temperature should be close to melt temperature.

Table 2 shows the recommended cylinder temperatures for different hardness ranges.

Shore hardness	Heating zone temperature	Nozzle temperature
60 A - 80 A	170-210	200-210
85 A - 95 A	190-220	210-225
98 A - 74 D	210-230	220-240

Table 2: Guideline values for cylinder temperatures in °C (Please refer to the processing recommendations for the particular product.)

It is advisable to monitor temperature by measuring the melt temperature, and to make any necessary adjustments (see table 3).

Elastollan® hardness	Melt temperature
60 Shore A - 80 Shore A	190-205
85 Shore A - 95 Shore A	205-220
98 Shore A - 74 Shore D	215-235

Table 3: Guideline values for melt temperatures in °C

Elastollan® melts are shear-sensitive, and product properties can therefore be adversely affected by excessive screw rotation rates.

Figure 9 shows recommended screw rotation rates as a function of screw diameter.

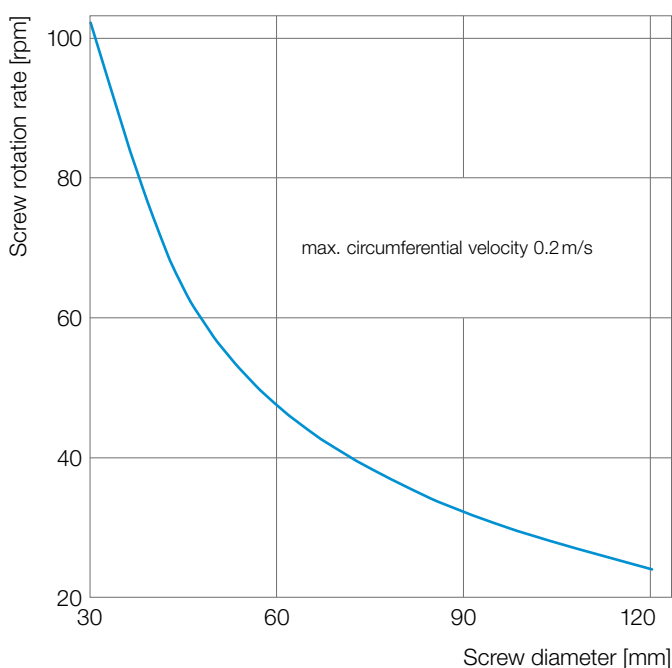

Fig. 9: Relationship of max. screw rotation rate to screw diameter

Prolonged stoppages lead to degradation of the material present in the cylinder. When stoppages exceed 10 minutes, the cylinder must be purged before production is resumed.

Other important machine parameters for processing of Elastollan® (see figure 10):

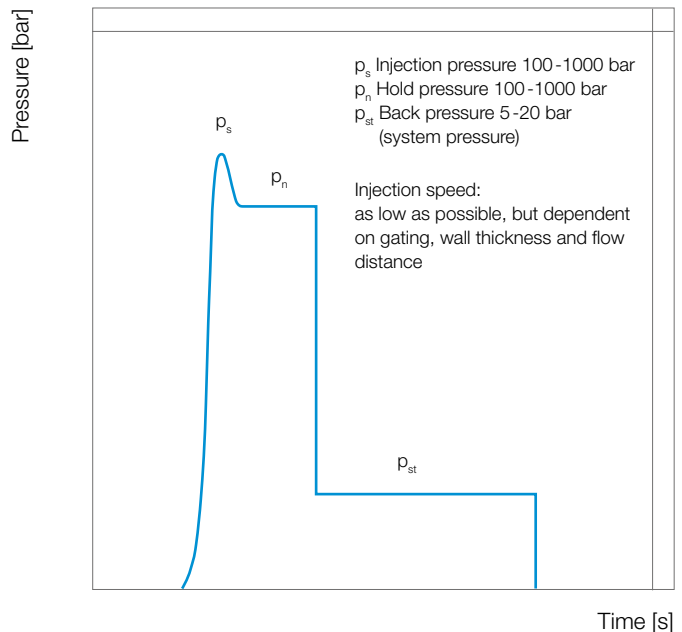

Fig. 10: Diagram of pressure sequence during processing

Injection Pressure and Hold Pressure

These influence the dimensional stability and ease of demolding of the products. Excessively low hold pressure leads to sink marks; excessively high injection pressure causes difficulties with demolding.

Back Pressure

This provides homogenization of the melt, but should not be excessive, because the material is shear-sensitive. A recommended back pressure is 5-10 bar, or up to 20 bar when additives are present.

Injection Speed

Injection speed depends on gating, wall thickness and flow distance. It should be kept as low as possible.

Figure 10 is a diagram of a typical cycle sequence for Elastollan®.

Cycle Times

Injection-molding cycle time is determined mainly by solidification and demolding behavior. It is substantially dependent on the hardness of the material, the wall thickness of the product and the temperature of the mold.

Figure 11 shows cycle time as a function of wall thickness for grades of different Shore hardness.

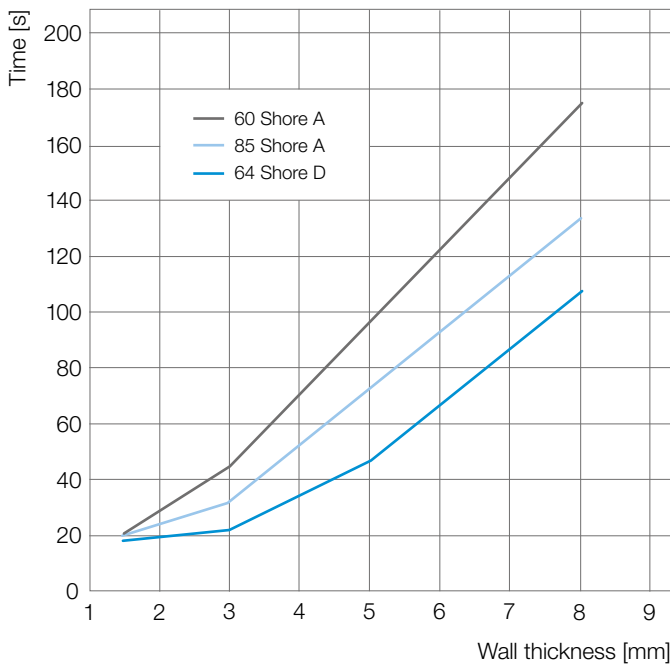

Fig. 11: Cycle times in relation to wall thickness (guideline values dependent on component design)

Mold Design

Materials for mold construction

The molds usually used for injection molding, made of steel or of steel alloys, are also suitable for processing of Elastollan®. Other molds successfully used are made of non-ferrous metals, preferably aluminum alloys. These lower-cost molds are frequently used in the shoe industry.

Sprues

The maximum sprue diameter should not exceed the maximum wall thickness of the molding. The diameter of the sprue cone should be adjusted to the nozzle and exceed the nozzle diameter by 0.5 mm. The gate should be located in the area of maximum wall thickness. Sprue cones should be as short as possible and with a minimum angle of 3 to 6°. A sprue puller is advisable for easier demolding.

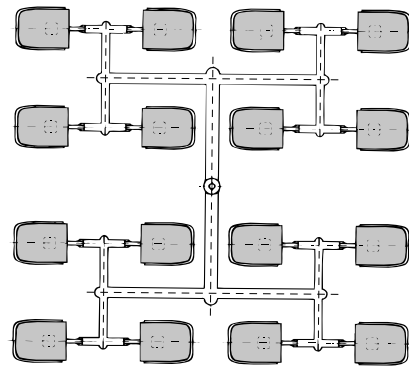

Fig. 12: Runner systems

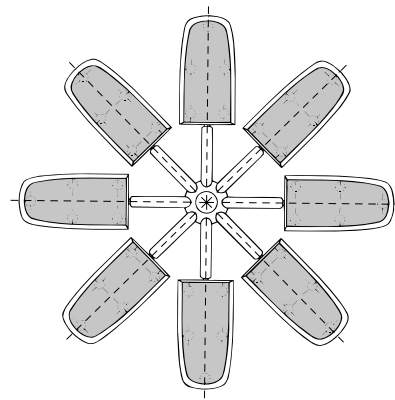

Fig. 13: Runner systems

Runners

The melt properties of Elastollan® require large-diameter runners to avoid localized shearing and to enable maximum pressure transfer to ensure mold filling. The best flow characteristics for Elastollan® are achieved by using a **circular runner cross section** (figure 14).

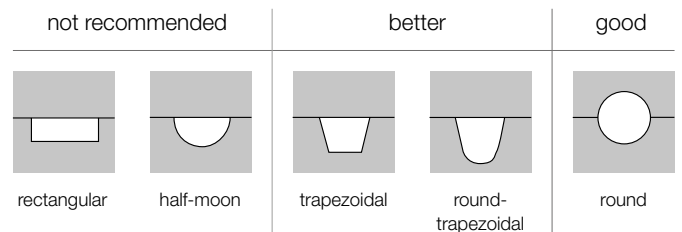

Fig. 14: Runner cross section

If **hot runners** are used, it is preferable to use **externally heated systems**. Internally heated systems are not suitable.

Multi-cavity molds need a balanced runner system.

Gating

Gates for processing of Elastollan® should be large, to ensure adequate holding pressure and to avoid sink marks.

Sprue gates, diaphragm gates, ring gates and film gates are often used. Small parts are also injected through pin gates.

Tunnel gates should be avoided, because of high elasticity and possible degradation due to shear. Softer Elastollan® grades are especially prone to problems with this type of gate.

Venting

To avoid air inclusions, or burn marks caused by compressed air, air present in the mold cavity must be able to escape easily at suitable points during injection of the melt. Vent channels of depth 0.02 to 0.05 mm and width 1-3 mm are usefully provided at the parting line, and at inserts and pins.

Mold Surface

Mold surfaces with average roughness height (R_z) of about 25 to 35 μm provide easy demolding during processing of Elastollan®, in particular the softer grades.

Polished and chrome-plated mold surfaces are less suitable. They tend to cause sticking on the mold surface, especially with soft grades.

Demolding

The flexibility of Elastollan® in the lower hardness region allows larger undercuts with easy demolding. Experience has shown that short-term overstretching by <5% does not lead to any lasting deformation.

To permit trouble-free demolding, ejectors should be two to three times larger than for hard thermoplastics. They should be provided with venting channels, so that no vacuum is generated during demolding.

Mold Temperature Control

A good mold temperature control system is essential for high-quality injection moldings, because mold temperature has a decisive influence on surface, shrinkage and warpage.

Usual mold temperatures are 15 to 70 °C, depending on molding and on Elastollan® grade. Product-specific data can be found in the respective product information.

Gate types recommended for Elastollan®

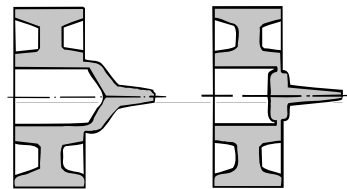

Fig. 15: Ring gate

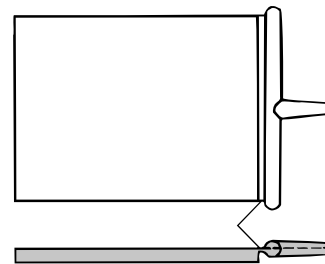

Fig. 16: Film gate

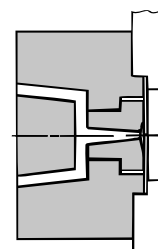

Fig. 17: Sprue gate

Shrinkage

Shrinkage during processing of Elastollan® is influenced by the following parameters:

- Product shape
- Wall thickness
- Gate design and position
- Type of material, processing conditions (particularly melt temperature), injection pressure, hold pressure, mold temperature.

Total shrinkage is a combination of molding shrinkage and a small degree of post-shrinkage, which occurs not only during annealing but also during prolonged storage.

The combined effects of these factors makes it difficult to predict shrinkage with any great accuracy.

Figure 18 shows total shrinkage in relation to wall thickness and Shore hardness for unreinforced Elastollan® grades.

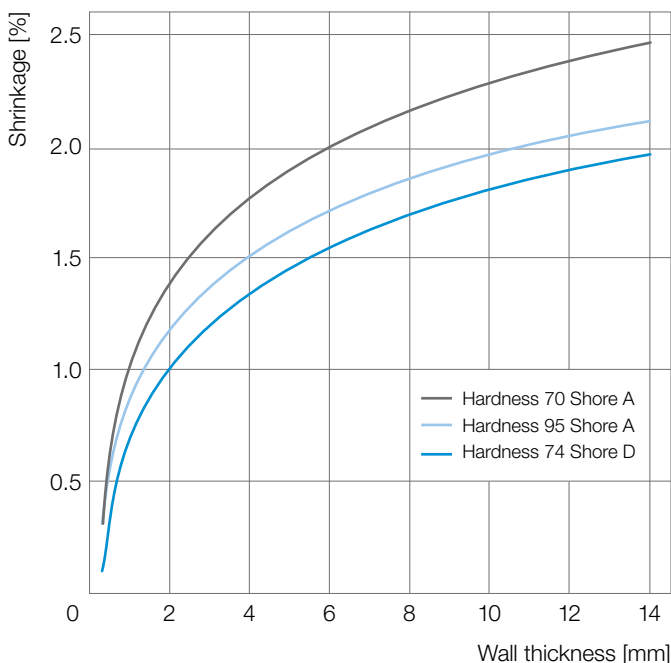

Fig. 18: Shrinkage in relation to wall thickness

Shrinkage in glassfiber-reinforced Elastollan® grades is dependent on glassfiber content: 0.05 to 0.2 % in flow direction and 0.1 to 0.5 % perpendicularly to flow direction.

Inserts

Excellent results can be achieved in molding around inserts. Metal inserts must be free from grease and have features to assist mechanical anchoring, for example holes, undercuts, knurled grooves, or notches.

Bonding can be improved by additional use of adhesion promoters. A small increase in the temperature of the inserts is helpful.

Special Processing Methods

Elastollan® can be combined with various plastics in the following special processing methods:

Multicomponent Injection Molding

Injection molding in multicomponent machines can achieve good bonding between Elastollan® and compatible plastics without use of additives or mechanical anchorage. Polyolefin-based plastics are not suitable for combinations with Elastollan®.

Sandwich Injection Molding

This is a special method of multicomponent injection molding where a core component is combined with a different plastics material as outer layer. Another possibility here, alongside combination of different plastics, is to use regrind as core component and virgin material as outer skin.

Thermoplastic Foam Injection Molding (TFIM)

Our product range includes grades specifically designed for TFIM, and also TFIM masterbatches which can be used with standard Elastollan® grades.

Troubleshooting

	Melt temperature	Mold temperature	Injection speed	Hold pressure/time	Back pressure	Shot size/Melt cushion	Clamping pressure	Cooling time	Venting	Moisture content	Contamination	Gate size	Lubricant	Residence time
Contamination											▼			▼
Bubbles/Blisters	▼		▼	▲	▲				▲	▼		▲		▼
Burnt spots	•	•	▼						▲	▼		▲		
Distortion/Shrinkage	•	•	•	●				●				▲		
Flow lines	●	•	•						▲	▼		▲		
Gloss/Matt surface	•	•	•	•					▲	▼		▲	•	
Flashing	▼	▼	▼	•			▲			▼		▲		
Short shot	▲	▲	▲	▲		▲			▲			▲		
Sink marks	•	•	•	▲		▲			▲	▼		▲		
Splay marks	▼	•	•						▲	▼	▼	▲	▼	▼
Demolding	•	●		•				●		▼		▲	▲	
Degradation	▼		▼		▼					▼		▲		▼

- ▲ Increase to solve problem
- ▼ Reduce to solve problem
- Increase or reduce to solve problem

Table 4: Troubleshooting guidelines

Extrusion

Machine Design

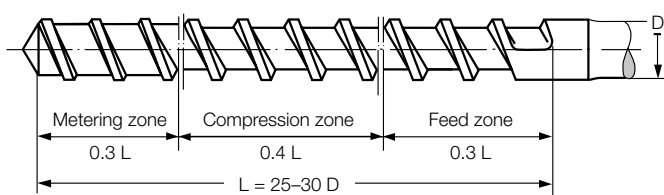

Fig. 19: Screw geometry (diagrammatic)

Single-screw extruders with compression ratio 1:2 to 1:3, preferably 1:2.5, should be used for processing Elastollan®.

The most suitable screws are three-zone screws with L/D ratio 25 to 30.

The three-zone screws should have a continuous constant pitch of 1 D.

Radial clearance between screw and barrel should be 0.1 to 0.2 mm. Multizone screws, e.g. barrier screws (undercut ≥ 1.2 mm) can also be used for processing of Elastollan®. However, short screws with a high compression ratio are not suitable.

Continuous purging can be ensured, and dead spots avoided, by designing the rear flight face with flatter radius than the thrust flight face.

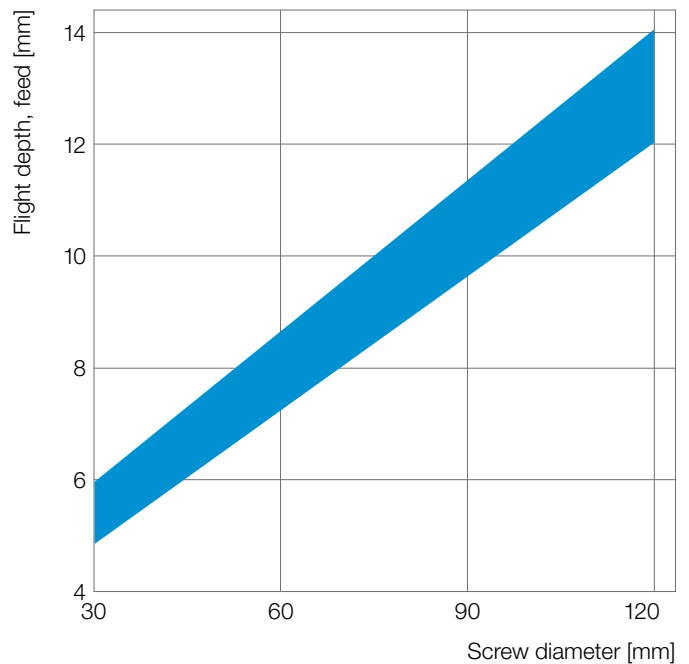

Fig. 20: Relationship between screw diameter and flight depth at feed

Barrels with grooved feed zone have a proven record of success, and provide the following benefits:

- constant seed characteristics
- improved pressure build-up
- increased output.

When grooved feed zones are used, cooling is necessary. It is also advisable here to use screws with mixing sections to improve melt homogeneity. However, these mixing sections should be designed to avoid degradation caused by shear. Use of breaker plates with screen packs is recommended. Good results have been obtained from a combination of two 400 mesh/cm² screens as backing plates and two fine 900 mesh/cm² screens. Finer screens may be required for certain applications (e.g. film production).

Breaker plates should have holes of diameter 1.5 to 5 mm, depending on screw diameter and type of die.

Extrusion of thermoplastic polyurethane requires a more powerful motor than **for other thermoplastics**. Power consumption is between 0.3 and 1 kWh per kg output, depending on screw design.

Melt pumps have proven successful in achieving continuous melt flow.

Processing Parameters

Screw Rotation Rate

Thermoplastic polyurethanes are shear-sensitive, and excessive screw rotation rates may therefore lead to poorer product properties.

Figure 21 shows the relationship between maximal screw rotation rate and screw diameter.

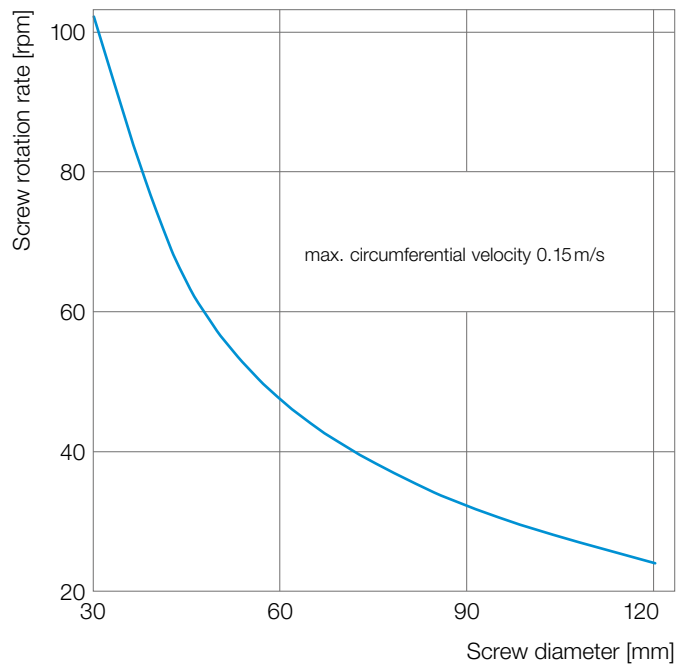

Fig. 21: Relationship of max. screw rotation rate to screw diameter

Processing Temperature

Recommended temperature ranges are as follows, depending on the hardness of the materials used:

Shore hardness	Heating zones			
	Barrel	Adapter	Die head	Nozzle
60-70 A	140-175	160-175	165-170	160-165
75-85 A	160-200	175-200	175-205	170-205
90-98 A	170-210	200-220	195-215	190-210
>98 A	200-220	220-240	210-230	200-230

Table 5: Guideline values for processing temperatures in °C

Melt Pressure

Melt pressure is dependent on head design and die gap, and on melt temperature. Pressure at the adapter is between 20 and 300 bar. Pressure peaks up to 1000 bar can occur at start-up. A continuously variable screw drive is therefore recommended for processing of Elastollan®; (it is also possible to use starve feeding if necessary).

Cleaning of Extruders

Extruder cleaning is recommended on change of material and after several days of continuous operation. A suitable material for this purpose is polypropylene or HDPE, both of which require relatively high processing temperatures. A cleaning compound can be used if necessary.

Die Design

For uniformity of melt flow it is important to operate with small cross sections which ensure uniform melt flow, and to avoid dead spots in the die. This ensures automatic self-cleaning of the die.

In all other respects, guidelines are the same as those for extrusion of other thermoplastics.

Figure 22 shows examples of typical extrusion dies.

For extrusion of tubing and profiles, dies with a relatively long land are recommended (figure 23). This reduces shear stresses, thus providing consistent output. Land length should be from two to four times nozzle diameter.

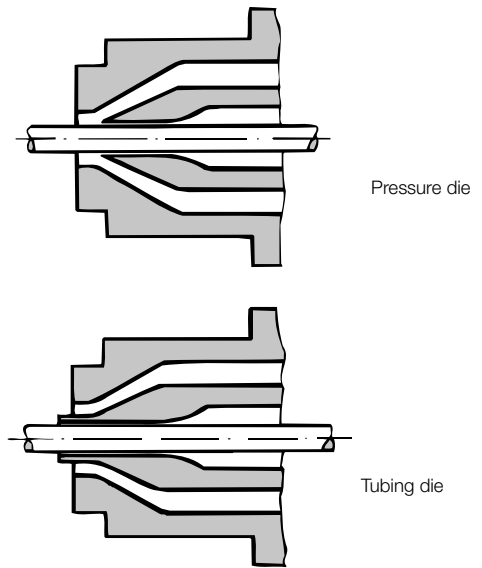

Fig. 22: Wire and cable sheathing dies

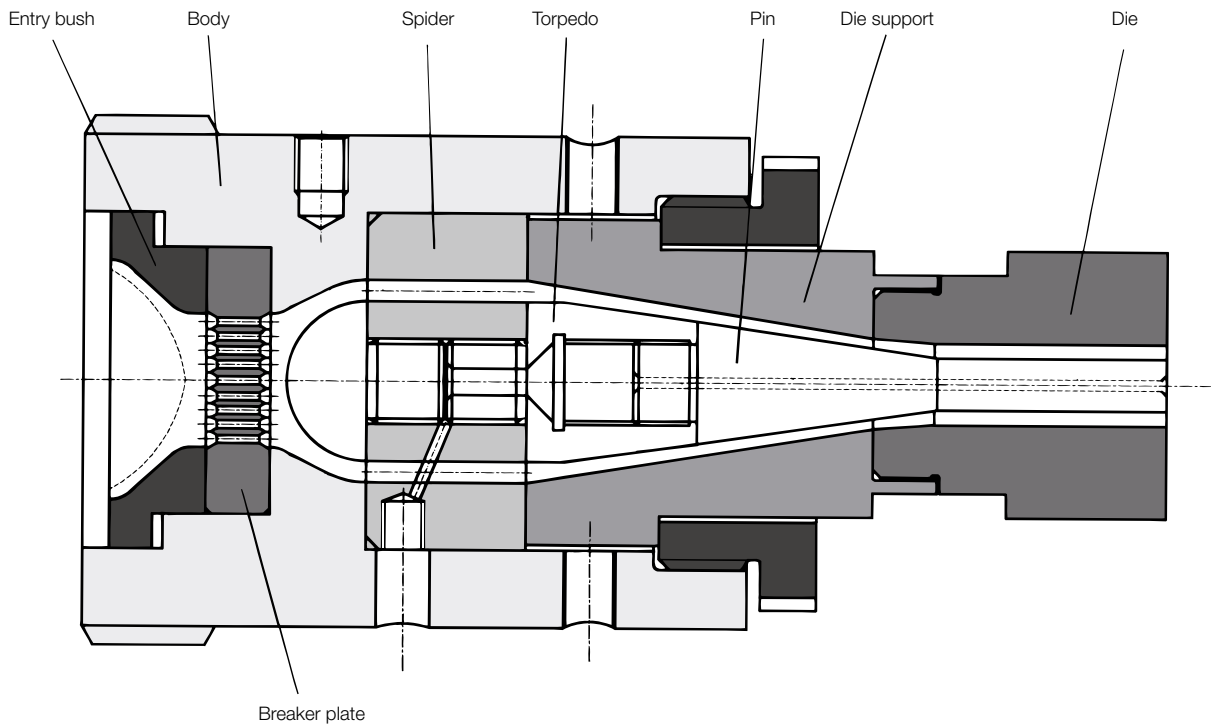

Fig. 23: Tubing extrusion die

Cooling and Calibration

Freshly extruded thermoplastic polyurethanes have relatively low melt strength and are therefore prone to distortion. This necessitates effected cooling. The water bath should be close to the extruder head. Chilled water is preferred. A cooling line with spray nozzles is a suitable alternative to cooling baths.

The cooling bath length required for Elastollan® grades is generally greater than for other thermoplastics. The length depends on hardness, wall thickness, geometry and haul-off speed.

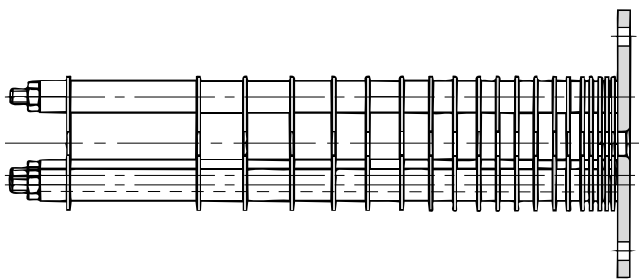

Fig. 24: Disc calibration

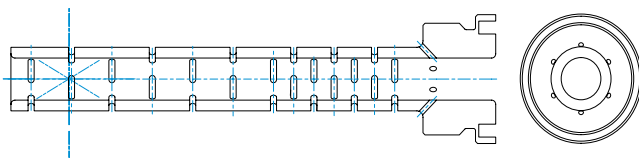

Fig. 25: Sleeve calibration

The active calibration used in processing of most other thermoplastics is not applicable to thermoplastic polyurethane, because of its high coefficient of friction. Calibration devices of the type shown diagrammatically in figure 24 (disc calibration) and in figure 25 (sleeve calibration) can provide the necessary guiding and support to the extrudate.

It is essential to provide a lubricating film of water between the surface of the extrudate and the calibrator. This can be achieved by using a water spray ring before entry into the water bath.

Figure 26 shows a typical layout of an Elastollan® tubing extrusion line.

Extrusion Techniques

Tubing and Profiles

Tubing and profiles are usually extruded horizontally. Thin-walled tubing and fire-hose linings are generally extruded vertically.

Introduction of supportive air is necessary in order to avoid collapse of the tubing.

Use of vacuum is recommended to increase the dimensional stability of hollow profiles.

Guide rollers in the cooling bath should be matched to the shape of the extrudate.

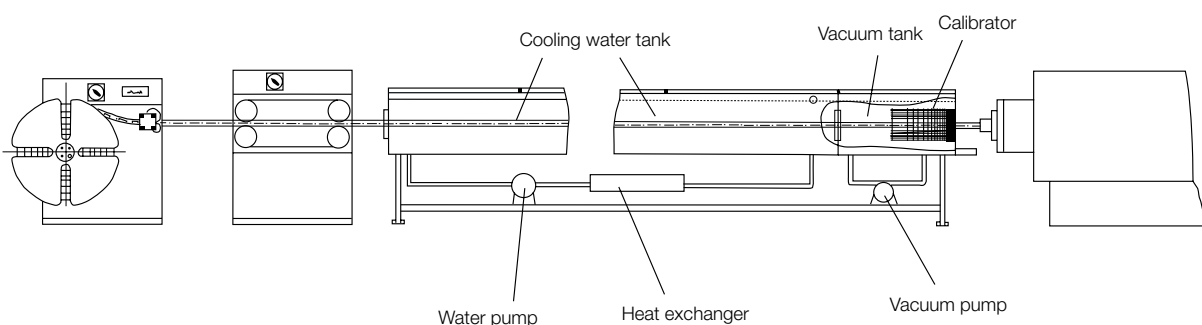

Fig. 26: Cooling bath for extrusion of tubing

Sheathing

For sheathing of cables, hoses, etc., a crosshead (see figure 27) equipped with a pressure die or tubing die (see figure 22) is normally used. To avoid blistering after extrusion and to ensure good adhesion, the inner core requiring sheathing must be dry and free from grease.

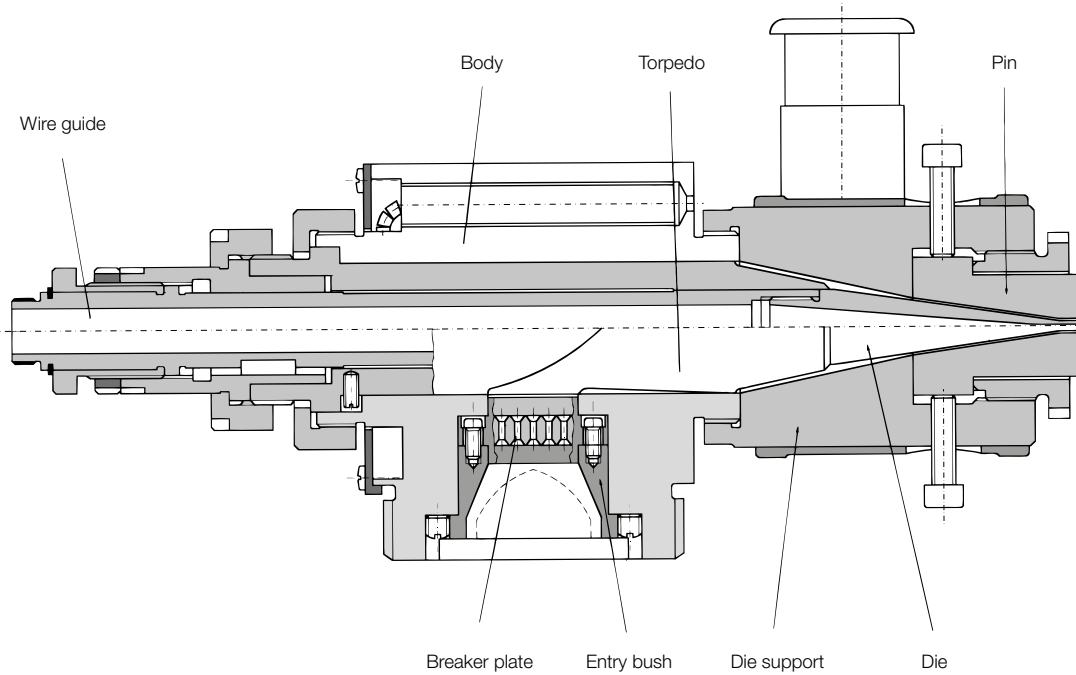

Fig. 27: Diagram of a crosshead

Films

Specific Elastollan® grades are suitable for blown film production. Figure 29 is a diagram of a film-blowing head.

Films of greater wall thickness can be produced by the flat film extrusion process with a sheet die (see figure 28); standard extrusion grades are suitable for this purpose.

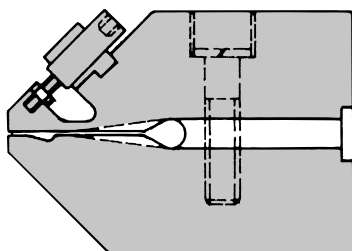

Fig. 28: Diagram of a sheet die

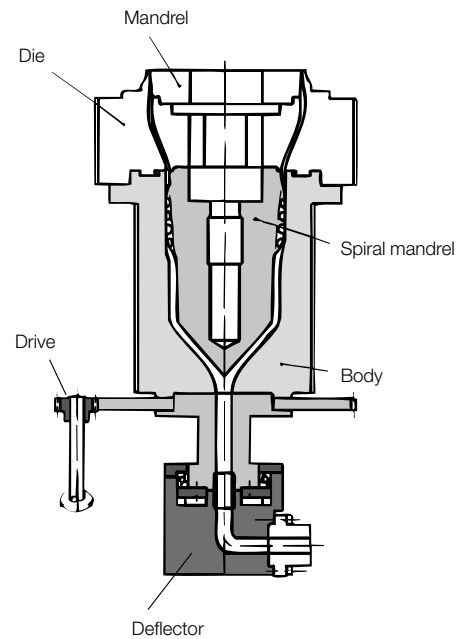

Fig. 29: Diagram of a film-blowing head

Blow Molding

Blow-molded products can be produced from particular Elastollan® grades in conventional blow-molding machines. Use of molds with roughened surfaces (approx. 25-35µm) is recommended for easier demolding. Wall thickness control is necessary to compensate for elongation of the parison. Figure 30 shows a torpedo head used for blow molding.

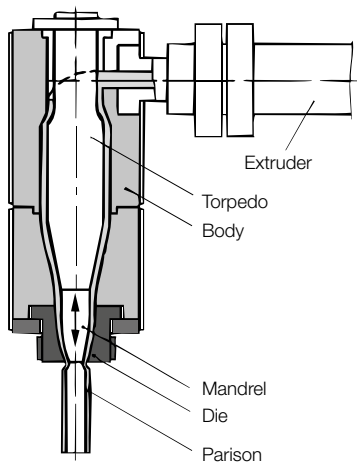

Fig. 30: Diagram of a torpedo head

Special Processing Methods

Elastollan® is suitable for the following special processing methods:

Coextrusion

to achieve a combination of properties of different thermoplastics in a single processing step.

Good bonding requires compatible materials; differences can arise here between ester- and ether-based Elastollan® grades.

Thermoplastic Foam Extrusion (TFE)

for weight reduction and to achieve specific properties.

Two methods are applicable:

- Chemical blowing of the melt through addition of blowing agent systems in conventional extruders; foam densities between 0.4 and 1.0g/cm³ are achievable.
- Physical blowing of the melt through injection of gas into the extruder. Foam densities below 0.4g/cm³ are achievable here; foam structure can be controlled by using a nucleating agent.

Troubleshooting

	Melt/ Barrel tempera- ture	Die tem- perature	Melt pressure	Screw rotation rate/ Output	Land length	Homo- geni- zation	Moisture content	Con- tamina- tion	Cooling of feed zone	Lubri- cant
Pulsation	●		•	▼		•	▼		●	▼
Rough surface	▲	▲		•	•	▲				▲
Surface streaks	▼	▼			•	▲	▼			•
Bubbles/Blisters	▼	▼	▲	▲			▼		▼	▼
Flow lines/ Spider lines	•		•	▼		▲	▼			
Excessive blocking	▼	▼	▲	▼			▼			▲
Unmelted particles	▲	▲		▼		▲		▼		
Dimensional variations	•	•	•	•	●	•	▼		•	▼
Insufficient dimensional stability	▼	▼	▲	▼	•		▼			
Melt fracture	▲	▲	▼	•	•	•				▲
Degradation	▼			•		▼	▼			

▲ Increase to solve problem | ▼ Reduce to solve problem | • Increase or reduce to solve problem

Table 6: Troubleshooting guidelines

Downstream Operations

Welding

A variety of welding methods can be used to weld semfinished and finished parts made of Elastollan®.

Injection-molded parts are mostly bonded by **hotplate**, **ultrasonic** (harder grades), **high-frequency** or **friction welding**.

Methods used for semfinished parts and profiles are **hotplate welding** and **friction welding**, and also **hot gas welding**.

For films, best results are achieved with **thermal sealing**, **heat-impulse welding** and **high-frequency welding**.

Factors decisively influencing **weld strength** are: **temperature** providing sufficient plastic flow of Elastollan® below decomposition temperature and **pressure** that generates melt flow and causes the boundary layers to flow, or diffuse, into one another. The pressure applied also serves to strengthen the weld during the solidification phase.

Adequate extraction of any vapors arising must be provided for all welding processes (see page 9 – Health & Safety at Work).

Bonding

Elastic polyurethane-based adhesives have proven successful for adhesive bonding of Elastollan® parts. For bonding to metals and other hard materials, epoxy resin adhesives are used.

The adhesive industry provides systems designed for these purposes.

The usual pretreatment methods should be applied before adhesive bonding.

Please note that good adhesive bonding is achievable only with lubricant-free Elastollan® grades.

Surface Finishing

Lubricant-free Elastollan® grades can be printed or painted.

Suitable printing and painting systems are available from manufacturers.

Machining Parameters

Because Elastollan® has exceptional toughness and tear strength, machining is not without problems, and much depends on the hardness of the material. With all tools used for machining of Elastollan®, care should be taken to ensure that cutting edges are correctly sharpened.

Excessive generation of heat during machining of Elastollan® must be avoided. Cooling by compressed air or emulsions should therefore always be provided.

Chipping Machining

Table 7 shows some guideline values for machining processes of Elastollan®.

		Turning	Milling	Drilling	Grinding
Clearance angle	α [°]	6-15	~10	12-16	–
Rake angle	γ	up to 25	15-25	10	–
Setting angle	χ [°]	45-60	–	–	–
Point angle	δ [°]	–	–	80	–
Cutting speed	v [m/min.]	100-200	200-500	40-50	30-50 m/s
Advance rate	s	0.1-0.4 mm/r	20-200 mm/min.	0.01-0.04 mm/r	max. 2/3 of grinding wheel width per tool rotation
Depth of cut	a [mm]	up to 15	2-8	–	0.1-3
Center radius	r [mm]	~ 0.5	–	–	–
Tool		HSS, SS, HM	HSS, SS, HM		

Drilling: Hollow drill, twist drill, tooth face-milling cutout

Grinding: High-porosity grinding wheel with open structure and low hardness (grain size 60-80)

Table 7: Machining parameters for Elastollan®

Drilling

Drilled holes are generally smaller than the nominal diameter of the drill. For grades up to 80 Shore A, the diameter reduction is about 4-5 %. Hollow drills give holes with greater dimensional accuracy.

Efficient cooling should be provided during drilling, and the drill should be raised frequently.

Turning

To reduce cutting forces and heat generated by cutting, tools used in turning processes should have smaller-diameter cutters than those used for metal.

Milling

Conventional milling machines and manual milling cutters may be used for Elastollan®. Where cutter heads are used, the number of blades should be minimized in order to ensure good chip formation.

Cutting

Cutting blades with close pitch and large setting are suitable.

Grinding

Elastollan® grades can be ground.

To prevent the heating, grinding wheels should not be too wide (max. 20 mm). It is therefore advisable to apply cooling, which can also increase grinding speed.

Chipless Machining

Punching

The shape of the punched surface depends on the hardness of the material. Figure 31 shows the result of punching for soft and hard Elastollan® grades.

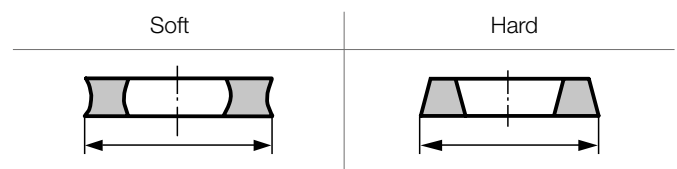

Fig. 31: Results of punching

Quality Management

Quality Guidelines

- Customers, processors and staff are all essential elements of Quality Management.
- We constantly monitor customer requirements and meet these with the aim of increasing customer satisfaction.
- Targets are agreed with staff in every one of our business sectors, and achievement is regularly assessed.
- Targets, methods and results of our Quality Management system are continuously studied with the aim of promoting awareness and engagement of all staff in the process of continuous quality improvement.
- Our guiding principle is avoidance of errors, rather than correction of errors after the event.
- Effective Quality Management guides an organization and staff in ensuring achievement of our quality objectives.

Management Systems/Certification

Customer satisfaction is the basis for sustained business success. Our aim is therefore to provide products and services that meet our customers' current and future expectations. To be sure of achieving this, several years ago BASF Polyurethanes GmbH introduced an integrated Quality and Environmental Management system covering every part of the business. Powerful performance indicators are used for regular assessment and improvement of every business activity. Our aim is optimized efficiency and coordination of all activities and procedures, bringing error level close to zero. Every member of staff is challenged to use his/her skills and ideas in contributing to quality assurance and continuous quality improvement.

Our integrated Quality and Environmental Management system is based on the requirements for the following standards:

DIN EN ISO 9001:2015

DIN EN ISO 14001:2015

DIN EN ISO 50001:2015

IATF 16949:2016

DIN EN ISO 45001:2018

For your notes

Index of Key Terms

Index of Key Terms

Additives 6

Adhesive bonding 22

Annealing 7

Back pressure 11

Barrel/cylinder temperatures

– extrusion 17

– injection molding 11

Blow molding 21

Calibration 19

Circulating-air dryers 5

Coextrusion 21

Coloring 6

Cooling 19

Cutting 23

Cycle Times 12

Demolding 13

Die/mold design

– extrusion 18

– injection molding 12

Disposal 9

Downstream Operations

– surfaces 22

– other downstream operations 23

– machining 22

Drilling 23

Drying

– dryers 5

– drying parameters 5

– water content 5

Extrusion

– calibration 19

– cooling 19

– die design 18

– machine design 16

– processing 17

Extrusion techniques

– blow molding 21

– films 20

– profiles 19

– sheathing 20

– tubing 19

Film gate 13

Film production 20

Gating 13

Grinding 23

Health & Safety at Work 9

Hygroscopic properties 4

Injection cycle 12

Injection molding

– inserts 14

– machine design 10

– shrinkage 14

– processing 10, 11

– mold design 12, 13

Injection pressure 11

Injection speed 11

Inserts 14

Machine design

- extrusion 16
- injection molding 10

Melt temperatures

- extrusion 17
- injection molding 10

Milling 23**Moisture absorption 4****Mold surface 13****Mold temperature 13****Multicomponent injection molding 14****Post-treatment 7****Processing**

- extrusion 17
 - injection molding 10
- Profile production 19**

Punching 23**Quality Management 24****Regrind 6****Ring gate 13****Runners 12****Sandwich injection molding 14****Screw flight depth**

- extrusion 16
- injection molding 10

Screw gate 13**Screw geometry 10**

- extrusion 16
- injection molding 10

Screw rotation rate

- extrusion 17
- injection molding 11

Sheathing 20**Shrinkage 14****Special processing methods**

- extrusion 21
- injection molding 14

Storage 4**Surface finishing 22****Temperatures**

- extrusion 17
- injection molding 10

– drying 5**Thermoplast foam extrusion 21****Thermoplast foam molding (TFM) 14****Troubleshooting**

- extrusion 21
- injection molding 15

Tubing 19**Turning 23****Venting 13****Water content 5****Welding 22**

Selected product literature:

- Thermoplastic Polyurethane Elastomer (TPU) – Think, create, Elastollan®
- Elastollan® – Product Range
- Elastollan® – Material Properties

Note

The data contained in this publication are based on our current knowledge and experience. In view of the many factors that may affect processing and application of our product, these data do not relieve processors from carrying out their own investigations and tests; neither do these data imply any guarantee of certain properties, nor the suitability of the product for a specific purpose. Any descriptions, drawings, photographs, data, proportions, weights, etc., given herein may change without prior information and do not constitute the agreed contractual quality of the product. It is the responsibility of the recipient of our products to ensure that any proprietary rights and existing laws and legislation are observed. (September 2019)

Further information on Thermoplastic Polyurethane Elastomers (TPU) can be found on the Internet at:

www.elastollan.basf.de

Please also visit our websites:

www.plastics.basf.com

www.plastics.basf.de

Brochure request:

plas.com@basf.com

For technical queries relating to these products

Please use the Elastollan® Infopoint:

